

品番 No.	品名 NAME	材質 MATERIAL	個数 QUANT.	摘要 REMARKS	品番 No.	品名 NAME	材質 MATERIAL	個数 QUANT.	摘要 REMARKS
1	本体 BOX	溶融亜鉛鋼板 SGC	1	t0.6	3	屋根 ROOF	溶融亜鉛鋼板 SGC	1	t0.6
2	ドア DOOR	溶融亜鉛鋼板 SGC	1	t0.6	4	底板 BOTTOM	溶融亜鉛鋼板 SGC	1	t0.6

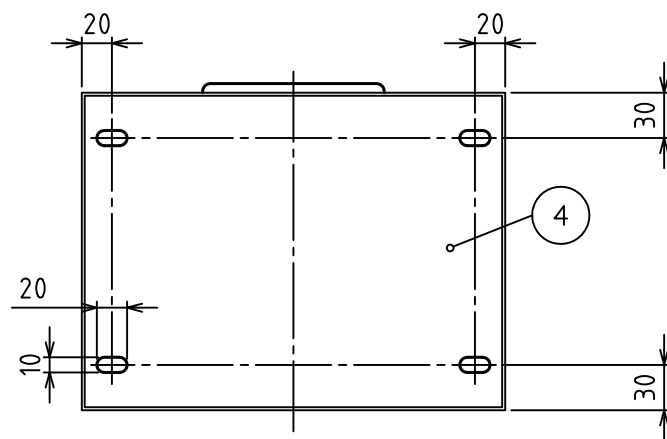
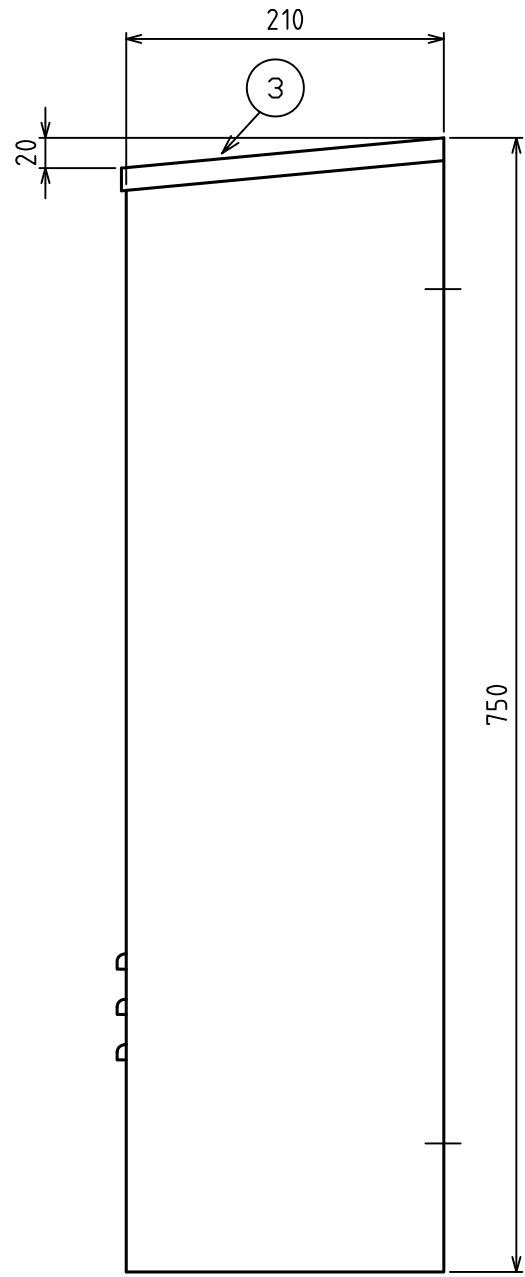
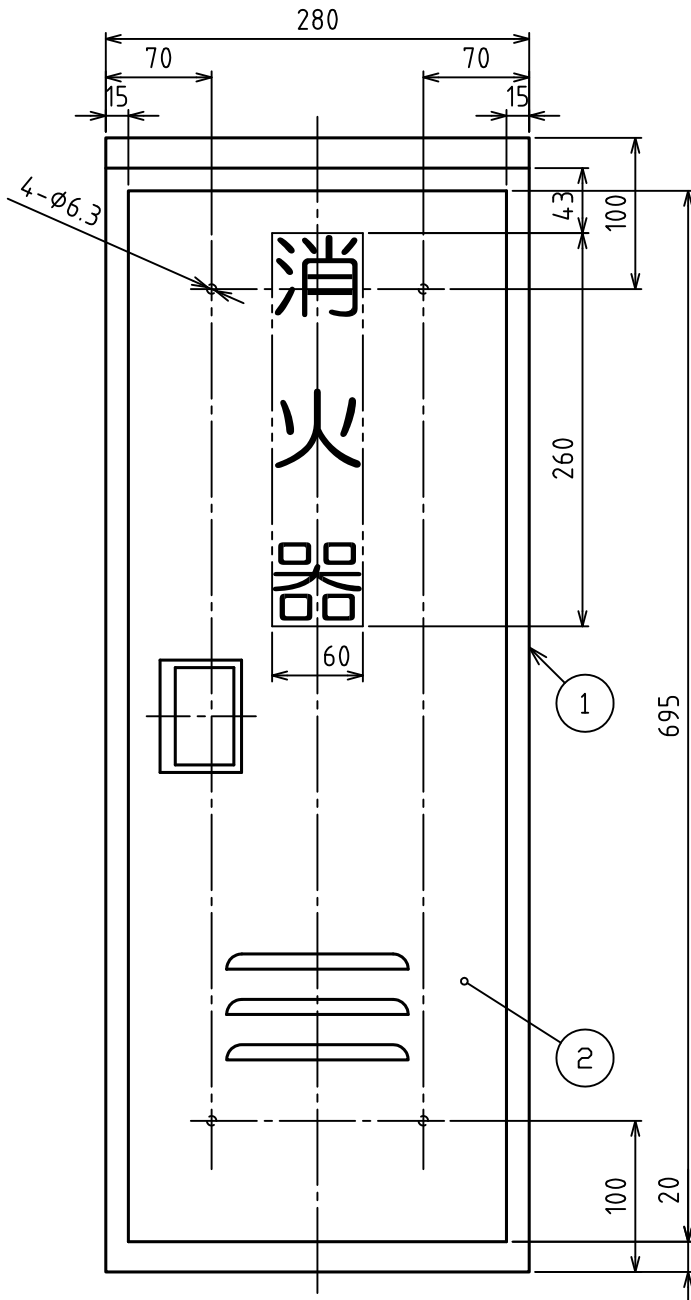

- * 質量：約4.5kg
- * WEIGHT：APPROX. 4.5kg
- * 塗装色：赤色（マンセル値：7.5R4/14）
- * PAINT COLOR：RED（MUNSELL No. 7.5R4/14）
- * 文字色：白色
- * LETTER COLOR：WHITE

消火器格納箱 FIRE EXTINGUISHER BOX		名称 NAME	NB-201（Ⅱ）	
NDC 日本ドライケミカル株式会社 NIPPON DRY CHEMICAL CO., LTD.	年月日 DATE	2011/11/7	品目コード CODE No.	405201
	図番 DRAWING No.	EB-201 (2)		